

## Compact Circulation Heater Ideal Where Fluid Cleanliness, Temperature Accuracy and High Pressure are Needed

Watlow's new CAST-X SERIES 2000 circulation heater is an ideal heating solution for demanding applications. The CAST-X SERIES 2000 heater consists of a helical coiled tube cast into an aluminum body with tubular elements. The aluminum body serves as the heat transfer media between the tubular element and the coiled tube through which the fluid being heated passes through.

The unique construction of the heater allows it to be used where thermally sensitive materials are being heated such as paints, resins and flammable materials such as fuels and solvents. The aluminum mass acts as a "thermal flywheel" and ensures accurate temperature control of the fluid to prevent degradation. The CAST-X 2000 is available with optional explosion proof enclosure for use in flammable environments.

The CAST-X 2000 is well suited to applications where fluid cleanliness is critical because the material being heated never comes in contact with the heating elements. This is a performance requirement in the foodservice equipment, semiconductor and analytical markets. The CAST-X 2000 heater comes with a heavy wall seamless stainless steel passageway that assures performance in high-pressure applications where viscous or mildly corrosive materials need to be heated.

### Specifications

- (4) ¼ - 20, ½ inch deep mounting holes
- Tubing - ½ inch dia. X 0.065 inch wall (12.7 mm x 1.65 mm)
- Wetted area - 316 stainless steel
- Process tube length - 150 inch (3.81m)
- NEMA 1 metal enclosure
- Up to 6000 watts, 3-phase
- Maximum working fluid pressure - 5000 PSI (344 Bar, 34 MPa)
- Maximum working temperature - 93°C (200°F), 260°C (500°F) with stand-off housing

### Standard Options

- NEMA 1, 4 and 7 enclosures with and without process thermostats
- Snap action high-limit thermostat
- Insulated body
- Process and high-limit thermocouples

### Non-standard Options

- ATEX explosion-proof enclosures
- Passivated or electropolished wetted surfaces
- Custom fittings
- Custom sensors
- Stand-off housing



### Features and Benefits

#### Fluid path independent of heater sheath

- Allows sensitive materials to be heated safely
- Prevents fluid contamination

#### Robust cast-in aluminum construction

- Assures longer heater life
- Accurate temperature control

#### Integrated thermostat and housing

- Assures easy use and installation
- Allows heater to run dry
- Protection in explosive environments

#### Standard stainless steel fluid path

- Assures material compatibility with many different materials

#### Non-welded construction

- Offers economical package price
- Minimizes potential leakage
- High pressure operation
- Self draining when mounted vertically

### Applications

- Solvent heating
- Glycol heating for heat transfer systems
- Sample heating - analytical instrumentation
- Steam generation
- Food and beverage heating - pasteurization
- Paint heating
- Two part urethane and foam system heating
- Air, CO<sub>2</sub>, and Nitrogen
- DI water heating

**Note:** Consult factory for other required sizes or options.



## WATLOW

1310 Kingsland Drive  
Batavia, Illinois 60510 USA  
Phone: +1 (630) 879-2696  
Fax: +1 (630) 879-1101  
Internet: [www.watlow.com](http://www.watlow.com)  
e-mail: [info@watlow.com](mailto:info@watlow.com)

BAT-CX2000-0605



## Wiring

- Interconnect either a single or double pole thermostat with a single-phase heater when the supply voltage does not exceed 277V~(ac) for SPST or 480V~(ac) for DPST
- Only interconnect three-phase delta heaters to DPST thermostats
- Use a single pole thermostat for pilot duty where the thermostat is not interconnected with the heater, or heater exceeds the volt/amp rating.
- In single phase applications one, two, or three elements may be connected in parallel.
- If selected, high limit snap action thermostat should be used for pilot duty only.
- On the drawings below, the dashed lines represent components or wiring supplied by the customer

## Configurable Enclosure / Thermostat Options

Description	S2	S5	W2	W5	E1
300A = 6000 Watts, 480 Volts, 3 Ph (Delta)	2	6	2	6	2
300B = 2000 Watts, 480 Volts, 3 Ph (Wye)	3	7	3	7	3
300C = 6000 Watts, 480 Volts, 1 Ph (3 Elements)	1	5	1	5	1
300D = 4000 Watts, 480 Volts, 1 Ph (2 Elements)	1	5	1	5	1
300E = 2000 Watts, 480 Volts, 1 Ph (1 Element)	1	5	1	5	1
300F = 6000 Watts, 240 Volts, 3 Ph (Delta)	2	6	2	6	2
300G = 2000 Watts, 240 Volts, 3 Ph (Wye)	3	7	3	7	3
300H = 6000 Watts, 240 Volts, 1 Ph (3 Elements)	1	5	1	5	1
300J = 4000 Watts, 240 Volts, 1 Ph (2 Elements)	1	5	1	5	1
300K = 2000 Watts, 240 Volts, 1 Ph (1 Element)	1	5	1	5	1
300L = 1500 Watts, 240 Volts, 1 Ph	4	5	4	5	4
300M = 1000 Watts, 240 Volts, 1 Ph	4	5	4	5	4
300Q = 4500 Watts, 208 Volts, 3 Ph (Delta)	2	6	2	6	2
300R = 1500 Watts, 208 Volts, 3 Ph (Wye)	3	7	3	7	3
300S = 4500 Watts, 208 Volts, 1 Ph	4	5	4	5	4
300T = 3000 Watts, 208 Volts, 1 Ph	4	5	4	5	4
300U = 1500 Watts, 208 Volts, 1 Ph	4	5	4	5	4
300N = 1500 Watts, 120 Volts, 1 Ph	4	5	4	5	4
300P = 1000 Watts, 120 Volts, 1 Ph	4	5	4	5	4

### SPST, 1-Phase (1)

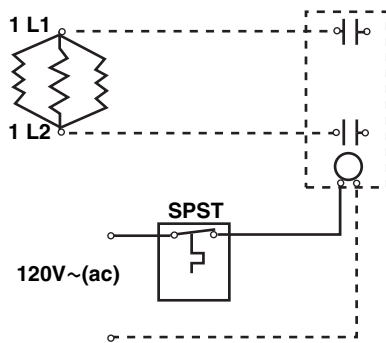

### SPST, 3-Phase Delta (2)

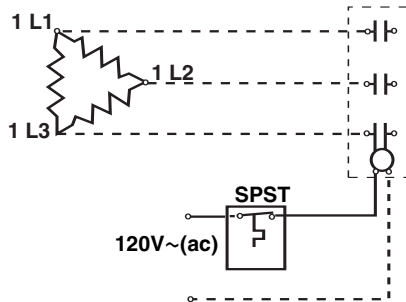

### SPST, 3-Phase Wye (3)

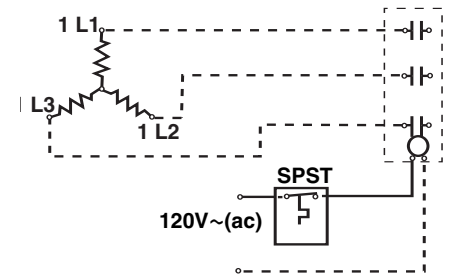

### SPST, 1-Phase (4)

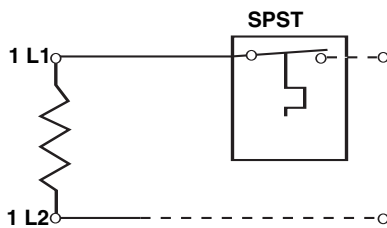

### DPST, 1-Phase (5)

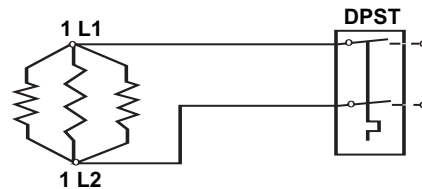

### DPST, 3-Phase Delta (6)

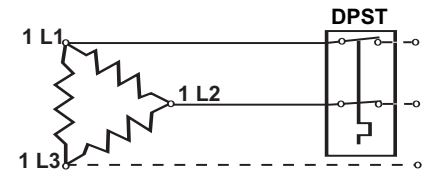

### DPST, 3-Phase Wye (7)

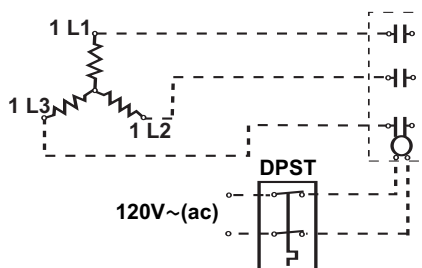

## Thermostat Ampacity Ratings

Description	Ampacity			
	Line Voltage			
	120 V	240 V	277 V	480 V
Single pole single throw for NEMA 1 and 4 housings	25	25	22	—
Double pole single throw for NEMA 1 and 4 housings	30	30	30	21
Single pole single throw for NEMA 7 housings	30	30	25	—
High limit snap action, single pole single throw	15	10	—	—

## Pressure Drop

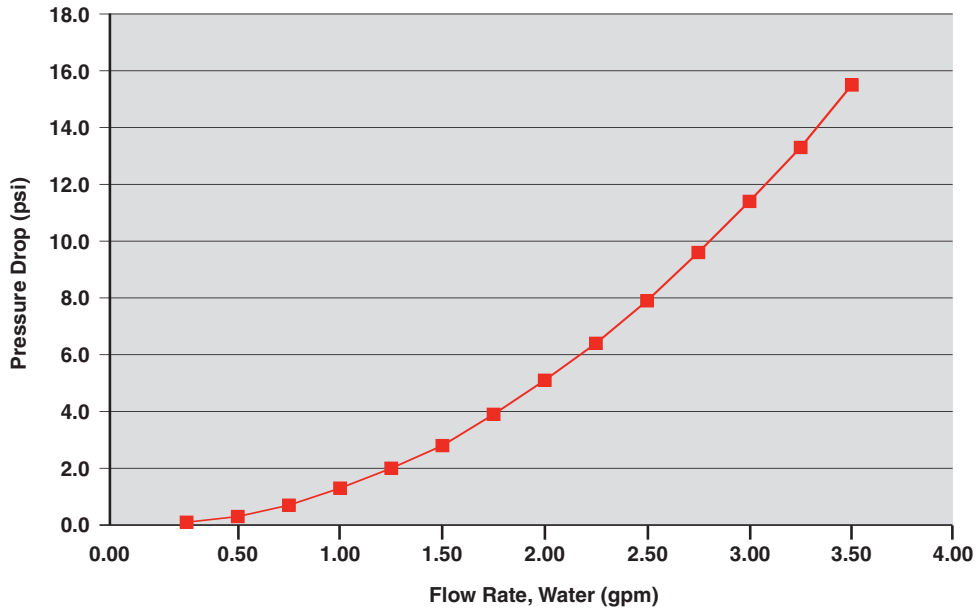

### NEMA 1 Housing With Single Pole Thermostat

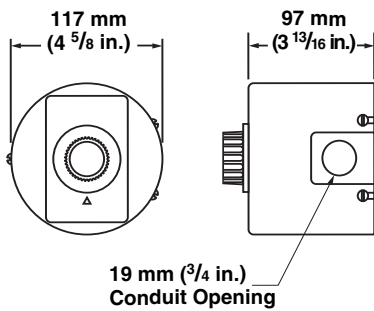

### NEMA 1 Housing With Double Pole Thermostat

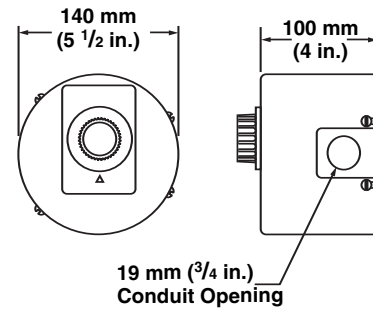

### NEMA 4 Housing With Single/Double Pole Thermostat

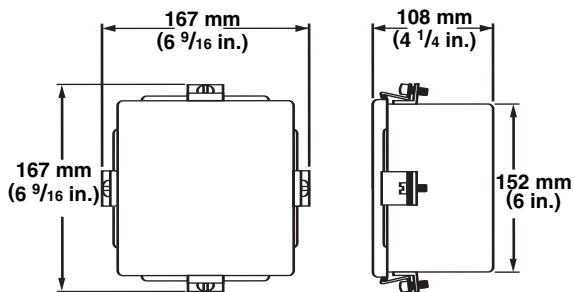

### NEMA 4 Housing Without Thermostat

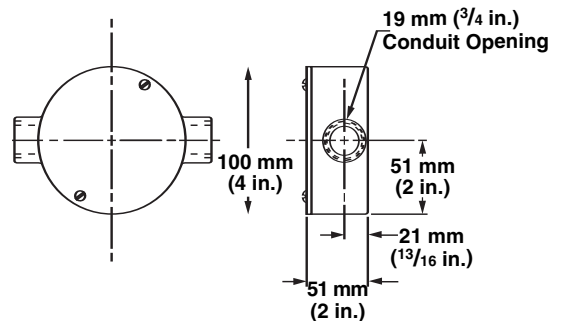

### NEMA 7 Housing With Single Pole Thermostat

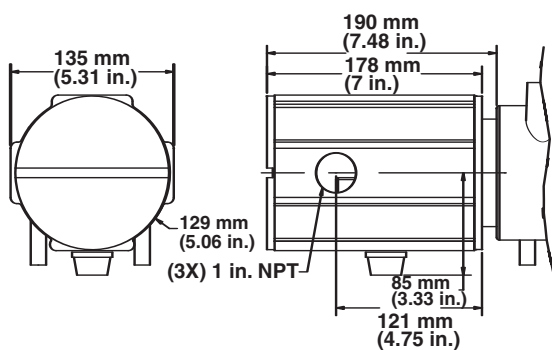

### NEMA 7 Housing Without Thermostat

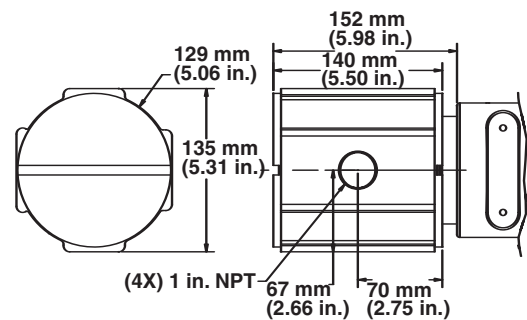

## Dimensions — Base CAST-X 2000

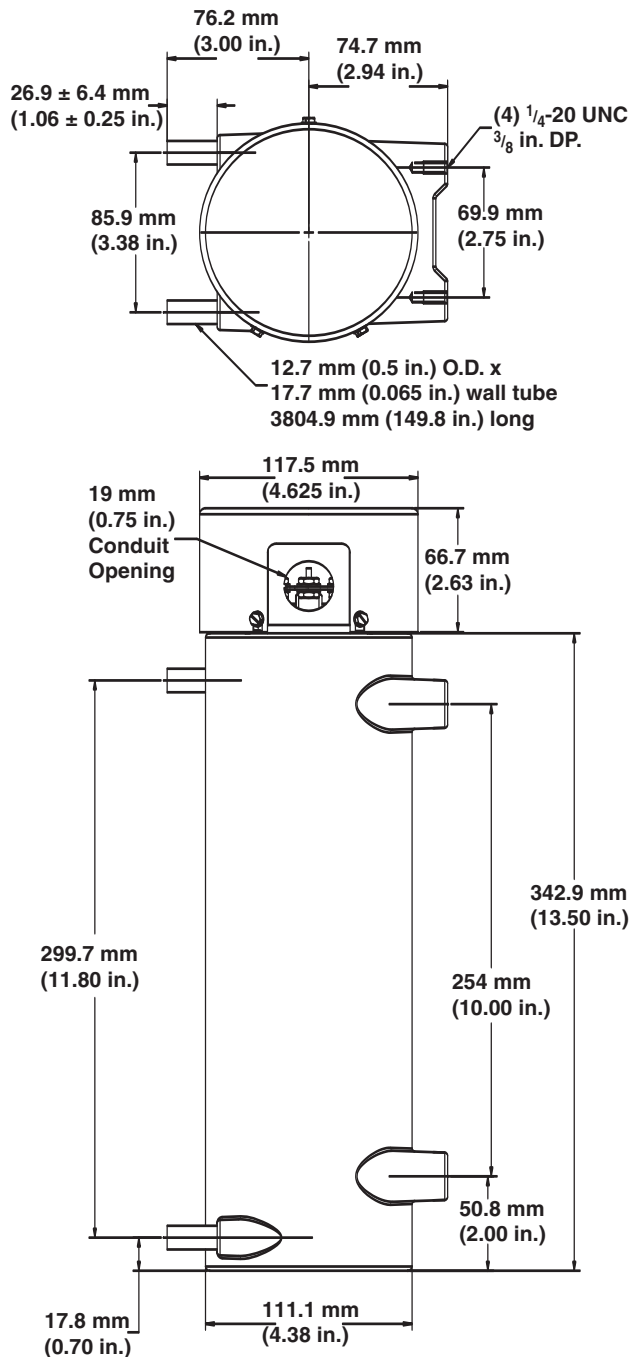

**Your Authorized Watlow Distributor Is:**

## Ordering Information

To order, complete the model number on the right with the information below.

**B X 1 3 J 4 G**

### Base Description

12.7 mm (0.5 in.) O.D. inlet/outlet, -17.7 mm (0.065) in. wall seamless 316 SS tubing, NEMA 1 housing

### Heater Wattage

300A = 480V, 6000W, 3-phase (Delta)  
 300B = 480V, 2000W, 3-phase (Wye)  
 300C = 480V, 6000W, 1-phase  
 300D = 480V, 4000W, 1-phase  
 300E = 480V, 2000W, 1-phase  
 300F = 240V, 6000W, 3-phase (Delta)  
 300G = 240V, 2000W, 3-phase (Wye)  
 300H = 240V, 6000W, 1-phase  
 300J = 240V, 4000W, 1-phase  
 300K = 240V, 2000W, 1-phase  
 300L = 240V, 1500W, 1-phase  
 300M = 240V, 1000W, 1-phase  
 300Q = 208V, 4500W, 3-phase (Delta)  
 300R = 208V, 1500W, 3-phase (Wye)  
 300S = 208V, 4500W, 1-phase  
 300T = 208V, 3000W, 1-phase  
 300N = 120V, 1500W, 1-phase  
 300P = 120V, 1000W, 1-phase

### Enclosures and Thermostats

S2 = NEMA 1 housing with -1 to 121°C (30 to 250°F) single pole thermostat  
 S5 = NEMA 1 housing with 16 to 121°C (60 to 250°F) double pole thermostat  
 W0 = NEMA 4 housing, no thermostat  
 W2 = NEMA 4 housing with -1 to 121°C (30 to 250°F) single pole thermostat  
 W5 = NEMA 4 housing with 16 to 121°C (60 to 250°F) double pole thermostat  
 WJ = NEMA 4 housing with Type J process T/C in t-well  
 WK = NEMA 4 housing with Type K process T/C in t-well  
 SJ = NEMA 1 housing with Type J process T/C in t-well  
 SK = NEMA 1 housing with Type K process T/C in t-well  
 EJ = NEMA 7 housing with Type J process T/C in t-well  
 EK = NEMA 7 housing with Type K process T/C in t-well  
 E0 = NEMA 7 housing with no thermostat  
 E1 = NEMA 7 housing with 10 to 121°C (50 to 250°F) single pole thermostat

### High Limit (Pilot Duty Only)

1 = Snap action high limit set at 127°C (260°F)  
 2 = Snap action high limit set at 260°C (500°F)

### Accessories

Compression fitting (high pressure) - 274-55-6-5  
 Insulation jacket - 307-0-11-1

To be automatically connected to the nearest North American Technical and Sales Office call:

# 1-800-WATLOW2

**International Technical and Sales Offices:** Australia, +61 (39) 335-6449 • China, +86 (21) 5211-0231 • France, +33 (01) 3073-2425 • Germany, +49 (0) 7253-9400-0 • Italy, +39 (02) 458-8841 • Japan, +81 (03) 3518-6630 • Korea, +82 (02) 575-9804 • Malaysia, +60 (4) 641-5977 • Mexico, +52 (442) 217-6235 • Singapore, +65 6773-9488 • Spain, +34 91 675 12 92 • Sweden, +46 31 7014959 • Taiwan, +886 (0) 7-288-5168 • United Kingdom, +44 (0) 115-964-0777